

Invisia™ Toilet Roll Holder

with Support Rail

INVISIA
LIVE BEAUTIFULLY

Technical Data Sheet

Product Specification

The product shall be a combination toilet roll holder and grab rail. The product shall be mounted to the wall using A discreet 0.125"/0.318cm thick plate and an additional contact point. The grab rail portion of the product shall be 1.25"/3.2 cm in diameter. The product shall be suitable for use in a wet environment. The product shall have a weight capacity in excess of 500lbs / 227kg. Product shall comply with ADA Guidelines, specifying the structural strength of grab bars, tubs and shower seats. The grab rail shall be Invisia Collection model INV-WTRH-____ (see table below for appropriate product code).

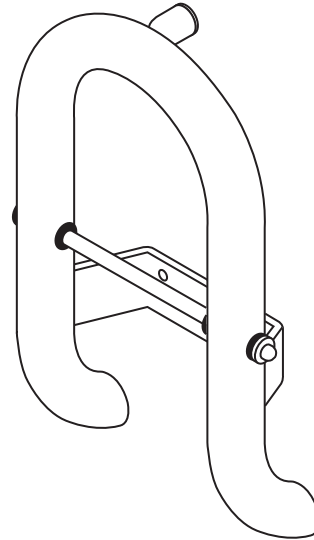

Key Features

- Elegant Design with Integrated Support
- Solid Construction and Mounting
- Discreet Wall Support
- Suitable For Use in a Wet Environment
- 500lbs / 227kg Weight Capacity

Codes and Standards

- ADA 609.2 Cross Section
- ADA 609.3 Spacing
- ADA 609.8 Structural Strength



Specified Model

Model	Finish	Material
INV-WTRH-BLK	Matte Black	#304 Stainless Steel
INV-WTRH-BS	Brushed	
INV-WTRH-CP	Polished Chrome	
INV-WTRH-ORB	Oil Rubbed Bronze	

Invisia™ Toilet Roll Holder

with Support Rail

INVISIA
LIVE BEAUTIFULLY

Technical Data Sheet

Product Dimensions

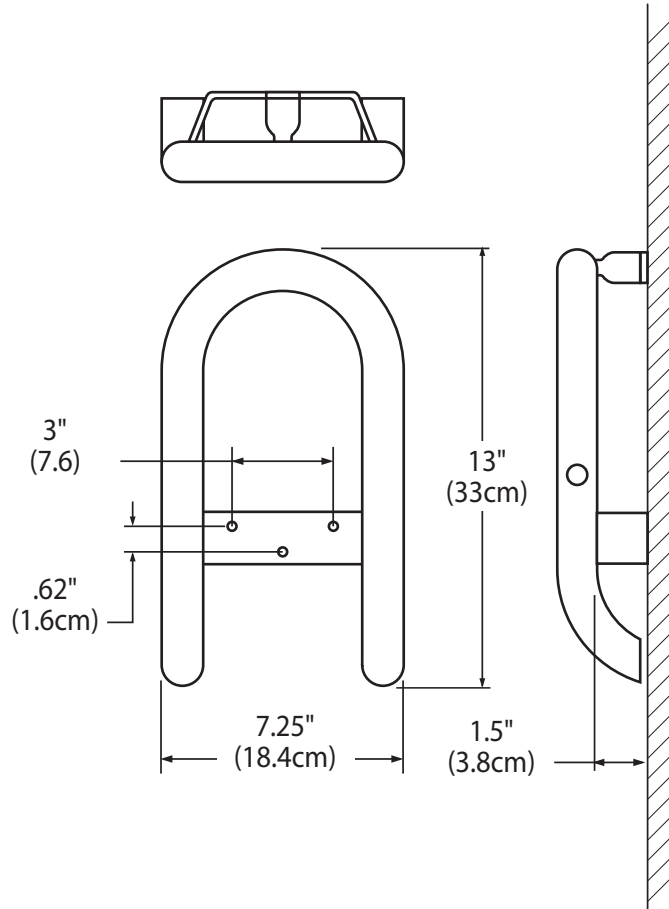

Shipping Dimensions

Model	Height (H)	Width (W)	Depth (D)	Weight
WTRH	3.5" / 8.9cm	22.5" / 57.15cm	7.75" / 19.69cm	3lbs / 1.5kg

